

Xenon Lamps for BARCO Digital Cinema Projector

DXL-9BAF

Technical Data

Input Power	W	-	595-850
Voltage	V	-	18.5
Current	A	-	46
Operating Range	W/A	-	850(W)
Lamp Length	mm	a	294
LCL	mm	b	123
Cold Arc Gap	mm	c	3.5
Cathode	Base Diameter	mm (Φ)	d
	Pin Diameter	mm (Φ)	e
	Pin Length	mm	f
Anode	Base Diameter	mm (Φ)	g
	Pin Diameter	mm (Φ)	h
	Pin Length	mm	i
Bulb diameter	mm (Φ)	j	42
Cable length	mm	k	140
Crimping terminal	mm	l	14-10

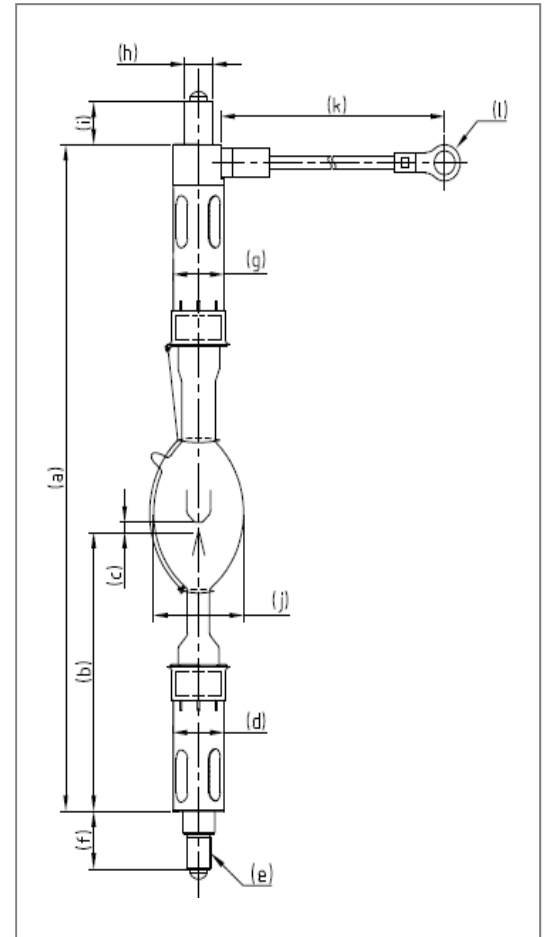

Warranty Hours

DXL-9BAF

3000

Cross Reference

Lamp Type

Projector Model

DXL-9BAF

DP2K-8S
DP2K-10S