

Xenon Lamps for NEC Digital Cinema Projector

DXL-15SN2

Technical Data

| | | | | |
|-------------------|---------------|--------|-------|----|
| Input Power | W | - | 1500 | |
| Voltage | V | - | 22 | |
| Current | A | - | 68 | |
| Lamp Length | mm | a | 423 | |
| LCL | mm | b | 171.5 | |
| Cold Arc Gap | mm | c | 3.5 | |
| Cathode | Base Diameter | mm (Φ) | d | 27 |
| | Pin Diameter | mm (Φ) | e | 20 |
| | Pin Length | mm | f | 18 |
| Anode | Base Diameter | mm (Φ) | g | 30 |
| | Pin Diameter | mm (Φ) | h | 14 |
| | Pin Length | mm | i | 18 |
| Bulb diameter | mm (Φ) | j | 42 | |
| Cable length | mm | k | (220) | |
| Crimping terminal | mm | l | 22-10 | |

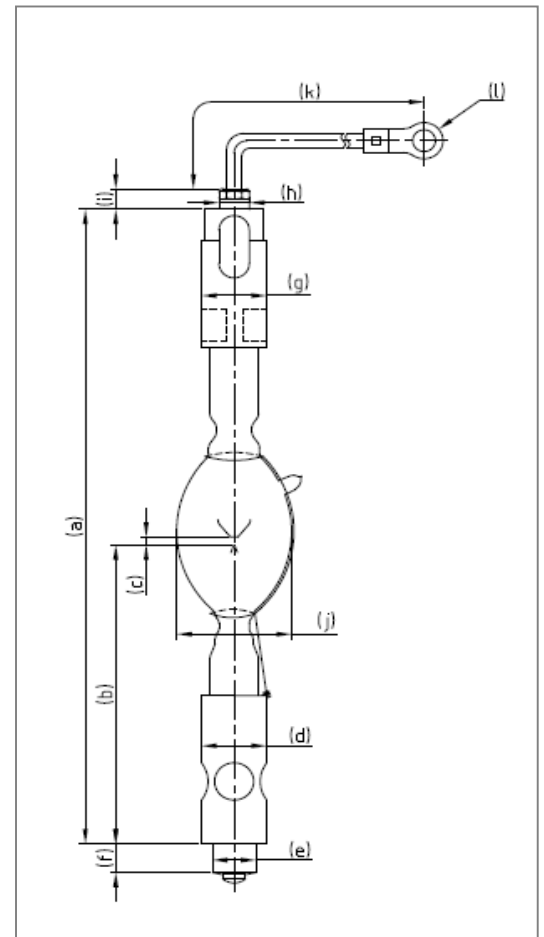

Warranty Hours

| | |
|-----------|------|
| DXL-15SN2 | 3000 |
|-----------|------|

Cross Reference

| Lamp Type | Projector Model |
|-----------|-----------------|
|-----------|-----------------|

| | |
|-----------|------------|
| DXL-15SN2 | NC2500S(*) |
| | NC3200S(*) |
| | NC3240S(*) |

*Combination of 4kw lamp power supply unit