

Xenon Lamps for BARCO Digital Cinema Projector

# DXL-22BAF

## Technical Data

Input Power	W	-	2200	
Voltage	V	-	26.5	
Current	A	-	83	
Operating Range	W/A	-	1540-2200(W)	
Lamp Length	mm	a	294	
LCL	mm	b	123	
Cold Arc Gap	mm	c	4	
	Base Diameter	mm (Φ)	d	27
Cathode	Pin Diameter	mm (Φ)	e	M12 × 1.75
	Pin Length	mm	f	14
Anode	Base Diameter	mm (Φ)	g	30
	Pin Diameter	mm (Φ)	h	14
	Pin Length	mm	i	19
Bulb diameter	mm (Φ)	j	53	
Cable length	mm	k	132	
Crimping terminal	mm	l	14-10	

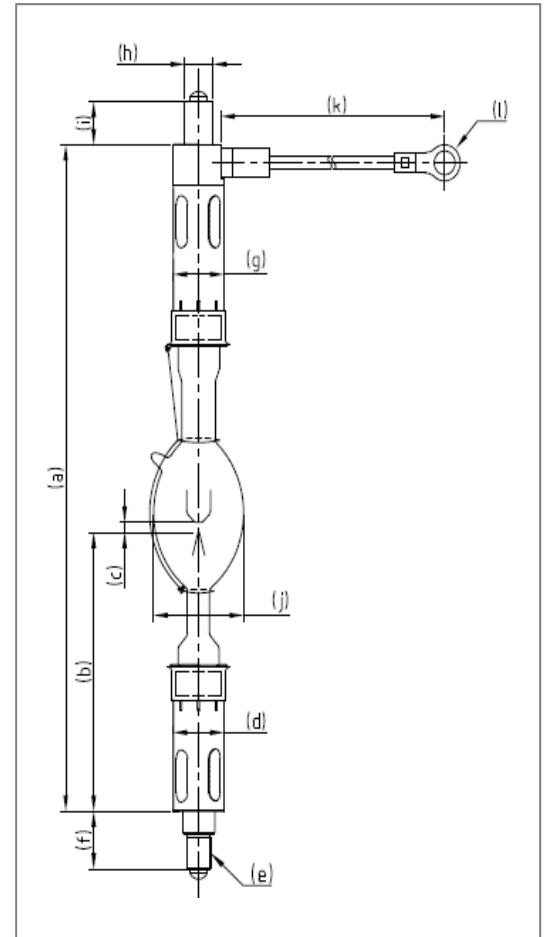

## Warranty Hours

DXL-22BAF	1500 (2000**)
-----------	---------------

\*The mentioned warranty hours in the brackets is for "burst".

## Cross Reference

Lamp Type	Projector Model
-----------	-----------------

DXL-22BAF

DP2K-10S