

Xenon Lamps for NEC Digital Cinema Projector

DXL-70SN

Technical Data

Input Power	W	-	7000
Voltage	V	-	40
Current	A	-	175
Lamp Length	mm	a	387
LCL	mm	b	171.5
Cold Arc Gap	mm	c	7.4
Cathode	Base Diameter	mm (Φ)	d
	Pin Diameter	mm (Φ)	e
	Pin Length	mm	f
Anode	Base Diameter	mm (Φ)	g
	Pin Diameter	mm (Φ)	h
	Pin Length	mm	i
Bulb diameter	mm (Φ)	j	80
Cable length	mm	k	220
Crimping terminal	mm	l	22-10

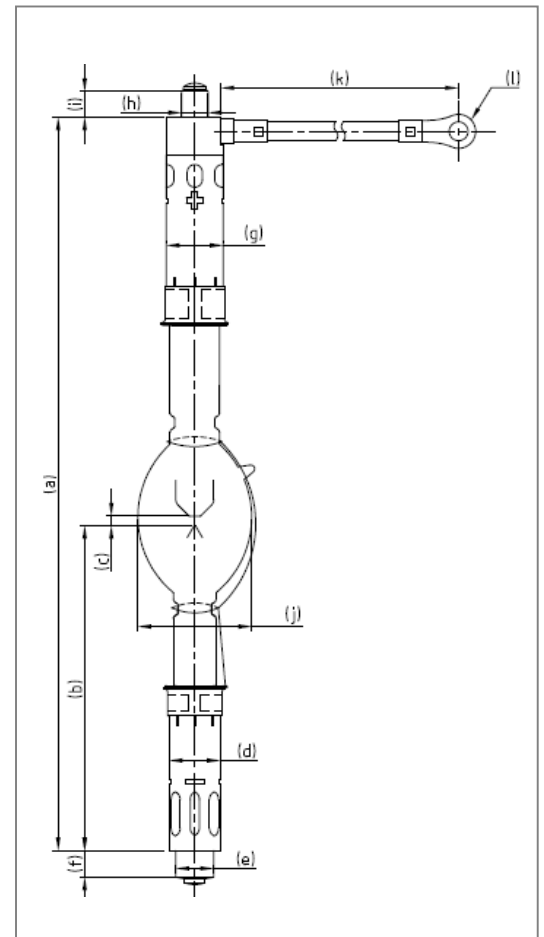

Warranty Hours

DXL-70SN

300

Cross Reference

Lamp Type

Projector Model

DXL-70SN

NC2500S(*)
NC3200S(*)
NC3240S(*)

*Combination of 7kw lamp power supply unit